

A Distinct Multipulse – Multilevel Converter for Especial Applications

Dr. K. Ravi Chandrudu ¹, K. Anusha ², P. Yohan Babu ³, G.V. Prasanna Anjaneyulu ⁴

^{1,2,3} Krishnaveni Engineering College for Women, Narasaraopet, Guntur, A.P., India.

⁴ Research Scholar, S.V.U. College of Engineering, S.V.University, Tirupathi, A.P., India

Abstract— This paper analyses the structure of an 12-pulse 7 level voltage source converter (VSC), assembled by combining one twelve-pulse VSC, in conjunction with an asymmetric single-phase seven-level converter plus an injection transformer. The device performance, proven on a lab prototype, allows verifying the harmonic content of the resultant voltage signal. The exhibited low THD, permits the system to be used in especial applications or as basement of FACTS devices. The three-phase digital PLL used to detect the phase of the fundamental voltage synchronizes the firing signals in all switches within a sample cycle. With this arrangement, the VSC output's total harmonic distortion in voltages is reduced, allowing it to be used in especial applications or as the basement of flexible A.C. transmission systems (FACTS) devices. The proposed strategy allows savings in the number of employed switches. Simulations and experimental results are provided to show the proposal appropriateness.

Index Terms— Voltage Source Converter, STATCOM, Flexible AC Transmission systems.

1 INTRODUCTION

The relationship between power quality and distribution system has been a subject of interest for several years. The concept of power quality describes the quality of the supplier voltage in relation to the transient breaks, falling voltage, harmonics and voltage flicker. Voltage Flicker is the disturbance of lightning induced by voltage fluctuations. Very small variations are enough to induce lightning disturbance for human eye for a standard 230V, 60W coiled-coil filament lamp.

This paper describes a strategy to generate the 84-pulse VSC, assembled with the combination of one 12-pulse converter with a seven-level converter, as well as one reinjection transformer to attain the required performance. The extra components are: 8 switches, 4 DC voltage sources, and 4 diodes for the seven-level converter. A reinjection transformer is needed, which is able to work properly within a wide range of its turn ratio. This constitutes an attractive array in terms of costs. In high-voltage applications, the voltage will generally be higher than the switches' and diodes' ratings at the current technology. Therefore, each symbol in the following diagrams may represent a chain of series-connected switches with auxiliary components. The disturbance becomes perceptible for voltage variation frequency of 10 Hz and relative magnitude of 0.26%. Huge non-linear industrial loads such as the electrical arc furnaces, pumps, welding machines, rolling mills and others are known as flicker generators. In this respect, the quality of supplied voltage is significantly reduced in an electrical power system and the oscillation of supplied voltage appears to be a major problem. Electric arc furnace, the main generator of voltage flicker, behaves in the form of a constant reactance and a variable resistance.

The Static Synchronous Compensator (Stat Com) is one of the most useful FACTS devices, since it can synthesize the reactive power from small storing elements. When it is operated within the linear region, it is seen by the system as a synchronous voltage source. By regulation of the Stat Com's output voltage magnitude, the reactive power exchange be-

tween the device and the transmission system may be controlled to improve the power system voltage profile. Since the Stat Com may cause interference on the system's fundamental sine wave at frequencies that are multiples of the fundamental one, especial care should be taken to ensure not to pollute the system to prevent further harmonic issues. In general, there are three feasible strategies to assemble a VSC: (i) the multipulse; (ii) the multi-level; (iii) and the pulse-width modulation (PWM). The transformer-reactance system is modelled as a lumped reactance, a furnace reactance (included connection cables and busses) and a variable resistance which models the arc. Connecting this type of load to the network produces voltage variation at the common point of supply to other consumers. The relative voltage drop is expressed by equation Strong efforts have been made in order to reach minimum harmonic distortion in the VSC's output voltage.

A strategy to build an 84-pulse equivalent output voltage waveform, which employs a twelve-pulse along with an eight-level reinjection converter, is presented in. However, the cost for this is 26 extra switch devices and 7 DC voltage sources (capacitors). This array makes the control task difficult because of the amount of gate signals needed, and it is prone to unbalance, due to the large chain of capacitors. Multi-Level Voltage Reinjection (MLVR) H-bridge conversion is another option to generate 84 pulses, which requires the use of 5 additional DC voltage sources and 12 switches, as opposed to the conventional 12-pulse converter. It may be easily utilized to attain more levels on the reinjection by adding H-bridges in series.

2 12 - PULSE 7 LEVEL-VOLTAGE SOURCE CONVERTER TOPOLOGY

Numerous methods have been investigated to increase the number of pulses in the multi-pulse converters' output. The

simplest one is by increasing the number of six-pulse converters and the corresponding transformers (4 six-pulses converter results in 24-pulse, 8 six-pulse converter results in 48-pulses operation, and so forth). The harmonic cancellation is carried out by the transformer secondary windings' arrangement. The weakness of this method is the large size and high cost due to the increased number of bridges and transformers. In order to overcome such difficulty, an auxiliary circuit in the DC link side has been proposed for reinjection. Such topology results through modifying the DC input on the conventional double bridge twelve-pulses shunt converters through a multi-level auxiliary circuit with an injection transformer.

In this paper, an asymmetric 7-level array for the auxiliary circuit is used as a reinjection scheme, Fig. 1. The conventional double bridge twelve-pulse operation is assembled by connecting two identical three-phase bridges to three-phase transformers in a parallel VSC configuration. Each branch in the six-pulse converter must have a displacement of 120° among them. The upper switch is conducting while the lower one is open and vice versa (180° voltage source operation) [14]. A 30° displacement in then firing sequence of both converters should be considered. Transformer's turn ratios are 1:1 and 1: 3 on the YY and YΔ transformers, respectively. By injecting additional DC pulses via the three-phase bridges' neutral point, an effect of pulse spreading is attained. The auxiliary circuit is common to the three phases, reducing the number of extra components. The configuration description to provide pulse multiplication is detailed in.

In Fig. 1, A-B illustrates the auxiliary seven-level inverter utilized as a reinjection circuit. To apply the seven-level inverter output voltage to feed the standard twelve-pulse converter, special care should be taken to not inject negative voltage into V_y or V ; notice the inclusion of the injection transformer between both arrays. Thus, voltages at the six-pulse converter inputs can be regulated by adjusting the injection voltage $i U$ by:

$$\begin{aligned} V_Y &= V_{DC} + U_i \\ V_\Delta &= V_{DC} - U_i \end{aligned} \quad (1)$$

The injection voltage is determined by the seven-level inverter switching pattern and the injection transformer turns ratio. By using voltages V_Y and V_Δ as inputs to the six-pulse converters, a cleaner VSC's output voltage comes about. Fig. 2 exhibits the followed strategy to build V_{YU} and $V_{\Delta U}$ as the interaction of the seven-level output and the corresponding six-pulse signals. Through the 1:1 ratio for the YY Transformer, 1: $\sqrt{3}$ for the YΔTransformer, and adding their corresponding output signals, the 84-pulse line-to-neutral signal emerges (Fig. 3a). The corresponding harmonic spectrum is depicted in Fig. 3b, illustrated on a linear scale, while the one presented in Fig. 4 is displayed in decibels. VU is an odd symmetric signal, so that the Fourier's even terms are zero. Thus

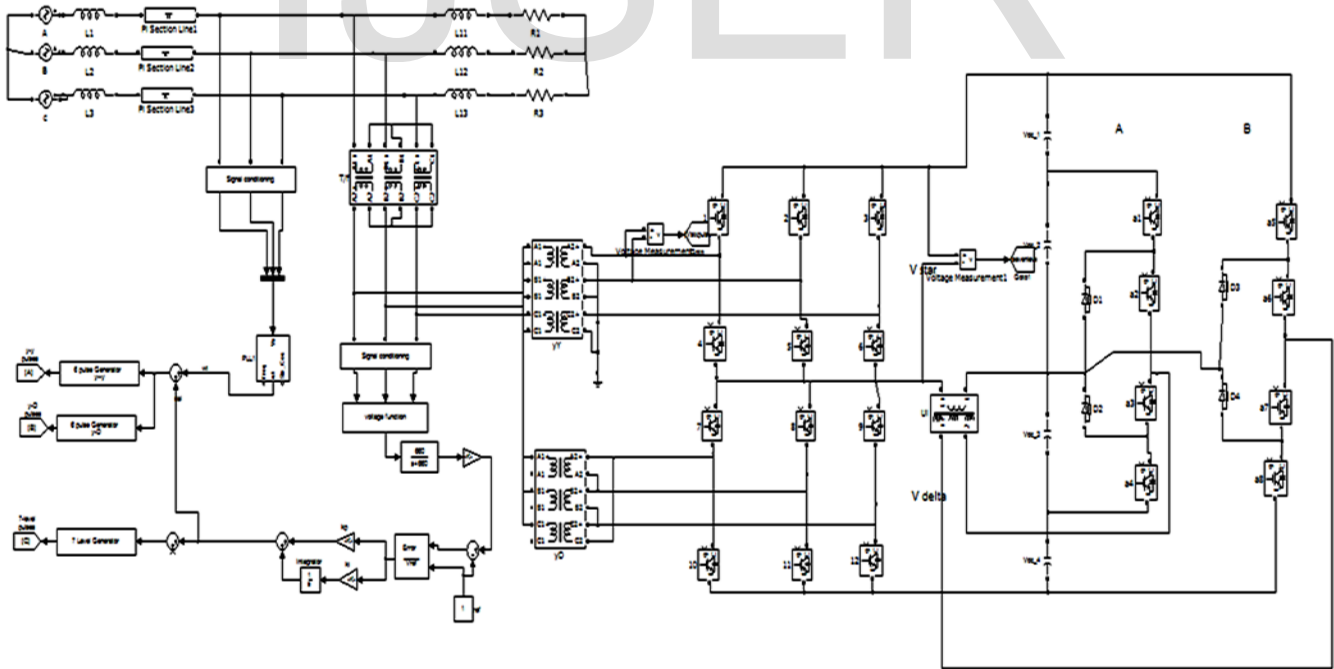

Fig.1: Twelve pulse seven level STATCOM structure

$$V_U(t) = \sum_{n=1}^{\infty} V_{U_{2n-1}} \sin((2n-1)\omega t)$$

$$V_{U_{2n-1}} = \frac{4V}{3\pi(2n-1)} (A_{2n-1} + aB_{2n-1})$$

$$A_{2n-1} = 2 + 2 \cos\left(\frac{1}{3}\pi(2n-1)\right) + 2\sqrt{3} \cos\left(\frac{1}{6}\pi(2n-1)\right)$$

$$B_{2n-1} = \sum_{i=0}^{20} \text{Coeff}'_i \cos\left(\frac{i}{42}\pi(2n-1)\right)$$

a is the reinjection transformer turns ratio.

$$\text{Coeff}' = \begin{Bmatrix} -3, & 1, & 1, & 1, & 1, & 1, & 1, & \dots \\ -3\sqrt{3}, & \sqrt{3}-1, & \sqrt{3}-1, & \sqrt{3}-1, & \sqrt{3}-1, & \sqrt{3}-1, & \sqrt{3}-1, & \dots \\ -3, & -\sqrt{3}+2, & -\sqrt{3}+2, & -\sqrt{3}+2, & -\sqrt{3}+2, & -\sqrt{3}+2, & -\sqrt{3}+2, & \dots \end{Bmatrix} \cdot \begin{Bmatrix} 1, & 1, & \dots \\ \sqrt{3}-1, & \sqrt{3}-1, & \dots \\ 2, & -\sqrt{3}+2, & \dots \end{Bmatrix}$$

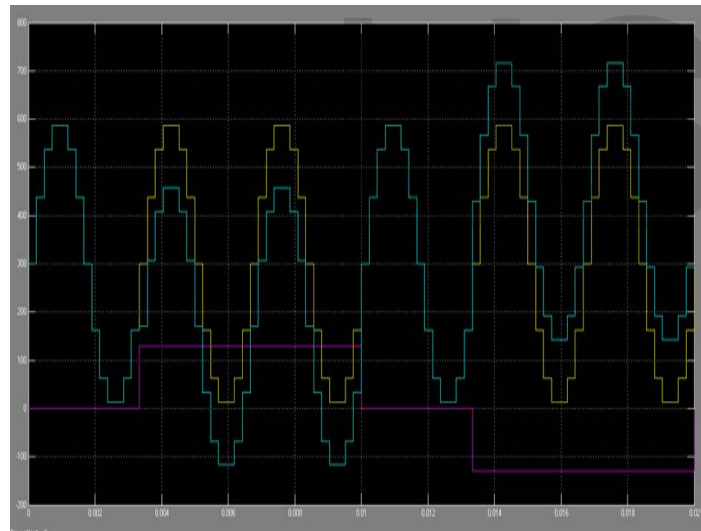

Fig. 2(a): Mixing seven-level, six-pulse signals, and transformer's ratios to attain V_{YU} and $V_{\Delta U}$

The 12-pulse seven level signal value (VU) depends on the injection transformer turns ratio a, which is determined so as to minimize the total harmonic distortion (THD), which is defined by:

$$\text{THD}_{VU} = \sqrt{\frac{\sum_{n=2}^{\infty} V_{Un}^2}{V_1^2}} \quad (2)$$

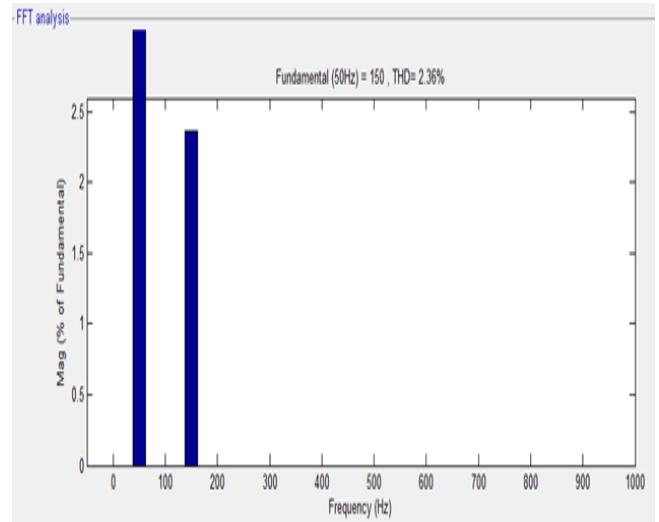

Fig. 2(b): Harmonic content

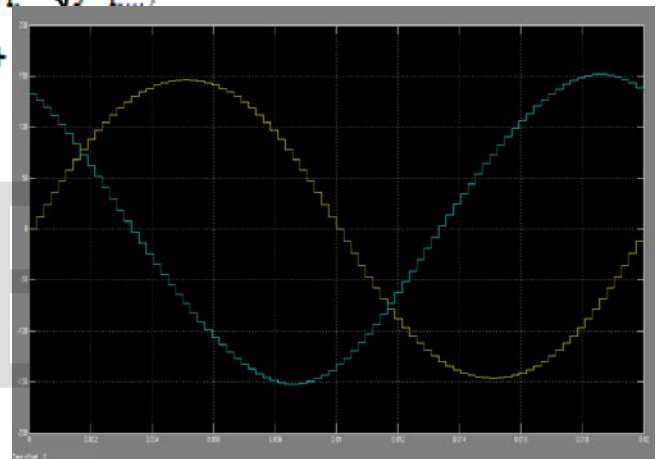
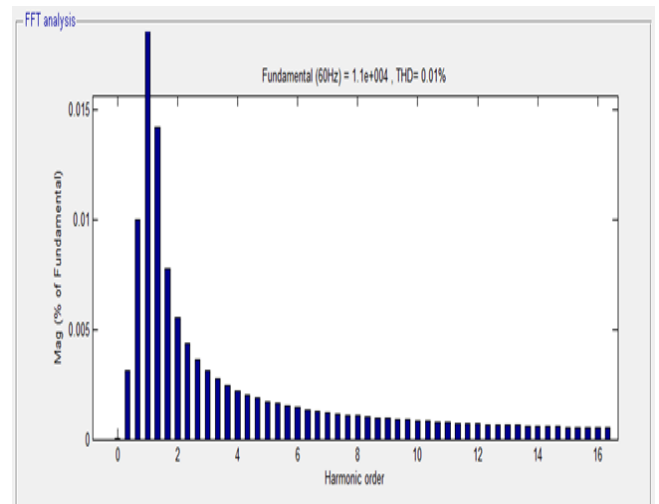

Fig. 3: 12-pulse seven level 3 phase output voltage

Fig. 4: Twelve pulse seven level harmonic content from



line to neutral in decibels

The minimization of THD yields the parameter a. In this paper such estimation has been made through MATLAB for a value

$n = 7200$, with increments of $a = 0.0001$. With these parameters, the minimum THD becomes 2.358% with $a = 0.5609$, value employed in previous figures. According to the IEEE Std. 519, the distortion limits indicate that the allowed THD voltage is 10% in dedicated systems, 5% in general systems, and 3% for special applications as hospitals and airports [17]. Table 1 presents the voltage's minimum THD generated by several multi-pulse configurations. Through our proposition, the resultant THD allows its use even in applications with stringent quality requirements; it exhibits less dependence to variations in the transformer's turn ratio a , which can have a variation until 12.5% to reach a maximum THD lower than 3%. This means that it does not need a strict reinjection transformer turn ratio in order to get the THD for stringent conditions.

Table 1: Minimum THD reached through VSC multi-pulses-based

| Number of pulses | THD (%) |
|------------------|---------|
| 12 | 15.22 |
| 24 | 7.38 |
| 48 | 3.8 |
| 60 | 3.159 |
| 84 | 2.358 |

3. SIX-PULSE GENERATOR

The second block is the six-pulse generator, responsible for generating the pulse sequence to fire the three-phase IGBT array. It consists of an array of six-pulse spaced 60° each other. The IGBT will operate at full 180° for the on period and 180° for the off period. Any disturbance on the frequency will be captured by the synchronizing block, preventing malfunctioning. The falling border in the synchronizing block output signal is added to a series of six 60° spaced signals. The modulus operator with the argument gives the needed on sequence that will be sent to the gate Opto-coupler block, which will feed each six-pulse converter. The off sequence turns out on a similar way but waiting 180° to keep the same on and off duration in each IGBT.

4. SEVEN-LEVEL PULSE GENERATOR

To operate the seven-level inverter, six times the frequency of the six-pulse generator must be ensured. This is achieved by monitoring the falling border in the novel PLL output signal, using it along with the modulus operator with the $\pi/3$ argument. This signal will be the period for the seven-level generator which will change its state each $\pi/42$ rad.

5. CONCLUSIONS

This paper describes the strategy to obtain an 84-pulse VSC three-phase voltage with the associated low THD, by combining one twelve-pulse converter plus a seven-level converter. The device performance, proven on a lab prototype, allows verifying the harmonic content of the resultant voltage signal. The exhibited low THD permits the system to be used in special applications or as basement of FACTS devices. The three-phase digital PLL used to detect the phase of the fundamental voltage synchronizes the firing signals in all switches within a sample cycle.

REFERENCES

- [1] Hingorani, N. G.: "FACTS Technology - State of the Art, Current Challenges and the Future Prospects," IEEE Power Engineering Society General Meeting, 24-28 June 2007, Tampa, Florida USA
- [2] Song, Y. H., and Johns, A. T.: 'Flexible AC transmission systems FACTS,' (IEE Power and Energy Series 30, 1999)
- [3] Acha, E., Fuerte-Esquivel, C. R., Ambriz, H., Angeles, C.: 'FACTS. Modelling and Simulation in Power Networks.' (John Wiley and Sons, LTD, 2004.)
- [4] Wang, H. F.: "Applications of damping torque analysis to StatCom control", Electrical Power and Energy Systems, Vol. 22, 2000, pp. 197-204.
- [5] CIGRE, "Static Synchronous Compensator", CIGRE working group 14.19, September 1998.
- [6] Hingorani, N. G., and Gyugyi, L.: 'Understanding FACTS,' (IEEE Press 2000).
- [7] El-Moursi, M. S., and Sharaf, A. M.: "Novel Controllers for the 48-Pulse VSC StatCom and SSSC for Voltage Regulation and Reactive Power Compensation", IEEE Transactions on Power Systems, Vol. 20, No. 4, November 2005, pp. 1985-1997
- [8] Davalos-Marin, R.: 'Detailed Analysis of a multi-pulse StatCom', Cinvestav - Internal Report. May 2003, available at
- [9] Pan, W., Xu, Z., Zhang, J.: "Novel configuration of 60-pulse voltage source converter for StatCom application," International Journal of Emerging Electric Power Systems, Vol 8, Issue 5, 2007, Article 7.
- [10] Liu, Y. H., Arrillaga, J., Watson, N. R.: "A New STATCOM Configuration Using Multi-Level DC Voltage Reinjection for High Power Application", IEEE Transactions on Power Delivery, Vol. 19, No. 4, October 2004, pp. 1828-1834.
- [11] Arrillaga, J., Liu, Y. H., Watson, N. R.: 'Flexible Power Transmission, The HVDC Options.' (John Wiley & Sons, Ltd, 2007, pp. 169-223.)
- [12] Liu, Y. H., Watson, N. R., Arrillaga, J.: "A New Concept for the Control of the Harmonic Content of Voltage Source Converters", The

Fifth International Conference on Power Electronics and Drive Systems, 2003, 17-20 Nov. 2003, pp. 793-798 Vol.1

- [13] Rodriguez, J., Sheng, L. J., Peng, F. Z.: "Multilevel inverters: a survey of topologies, controls, and applications," IEEE Transactions on Industrial Electronics, Volume 49, Issue 4, Aug. 2002 pp. 724 -738.
- [14] Krause, P. C., Wasynczuk, O., and Sud, S. D.: 'Analysis of Electric Machinery and Drive Systems, Second Edition,' (IEEE Series on Power Engineering, pp. 487, 2002)
- [15] Liu, Y. H., Perera, L. B., Arrillaga, J., and Watson, N. R.: "Harmonic Reduction in the Double Bridge Parallel Converter by Multi-Level DC Voltage Reinjection," 2004 International Conference on Power System Technology POWERCON 2004, 21-24 November 2004
- [16] Han, B., Choo, W., Choi, J., Park, Y., Cho, Y.: "New Configuration of 36-Pulse Voltage source Converter Using Pulse-Interleaving Circuit", Proceedings of the Eight International Conference on Electrical Machines and Systems 2005, September 27-29, 2005

IJSER